

**PLEASE READ THE INSTRUCTIONS BEFORE FITTING THE KIT**  
**If you have a problem, however small, call our Technical Department.**  
Tel:- 01925 636950. Fax:- 01925 243111. Mon - Thurs 8.30 - 5pm.

- 1 Remove the hose connecting the air filter box to the throttle body, and the hose from the plastic air intake, **Drawing A**.
- 2 To provide clearance for the filter, remove the plastic clip from the front of the battery carrier, and turn the battery terminal towards the rear of the car, **Drawing A**.
- 3 **IMPORTANT. BEFORE FITTING THE NEW INTAKE HOSE THE FOLLOWING OPERATION MUST BE CARRIED OUT, SEE DRAWING B.**  
**Using a small file, remove the section of plastic shown (approx. 3mm) from under the throttle quadrant.** This will provide clearance above the new hose clip.
- 4 Fit the small end of the new intake hose onto the throttle body / inlet manifold, **Drawing C**, making sure the top and bottom section of the clip are fully pushed on. Turn the hose clockwise **to fit flat on the fuel rail, Drawing C**. Push the hose fully on and at the same time tighten the hose clip **firmly**.
- 5 Fit the breather hose into the new intake hose. **Drawing C**
- 6 Fit the metal tube up to the step in the filter neck. Fit the metal tube into the intake hose and adjust the filter until the K&N logo is in the horizontal position. Tighten until filter just rotates, then one more turn (360 degree's). **No more. Don't overtighten the clips.**  
**Drawing C.**
- 7 **Cold air intake system**  
Remove the screw from the plastic air duct. Remove the duct from the front panel. Follow **Drawing D & E** for fitting the rubber cold air hose into the base of the duct.
- 8 With the hose fitted to the duct, feed downwards behind the grille to finish as in **Drawing E**. Replace the screw and fit the small curved section of rubber hose to the oval end of the plastic duct pointing towards the filter.
- 9 **Tuning**  
No adjustments are required.
- 10 **Filter maintenance**  
Under normal conditions clean and reoil the filter at approx. 40000 miles/65000 km.  
**Use only K&N cleaner** and oil and follow the instructions carefully.

**K&N filter are pre oiled ready to fit**

**The advantages of K&N's cold air intake system**

Cooler air, being denser, will show positive improvements in power over filter systems that draw hot air from the engine bay.

**This Kit Should Contain :-**

- 1 x Air filter.
- 2 x Rubber intake hoses.
- 1 x Rubber cold air hose.
- 1 x Instruction sheet.
- 1 x Instruction pack:-
  - 1 x Filter maintenance sheet.
  - 1 x K&N window sticker.
  - 1 x Million mile warranty card.
  - 1 x Leaflet.
- 1 x Fixing kit containing :-
  - 2 x Hose clips size 44.
  - 1 x Hose clip size 48.
  - 1 x Metal tube.
  - 2 x Plastic cable tie (4" long).
  - 1 x Plastic tube.

**FITTING YOUR OWN 57i KIT**

If no **it is essential** that the person fitting the kit (e.g. mechanic) **carefully follows these particular instructions** even if he has fitted K&N kits before. This will save you both time and money. Kits incorrectly fitted may show a loss in performance e.g. the positioning of the essential cold air hose, (flexi expandable and rubber hoses are used).

**A final check** under the bonnet by yourself with the instructions, would seem sensible.

**Please Note!**

The enclosed rubber hose has been folded for packing purposes. The hose will return to it's original shape if left in a warm area for 20 minutes, e.g. on top of a radiator.

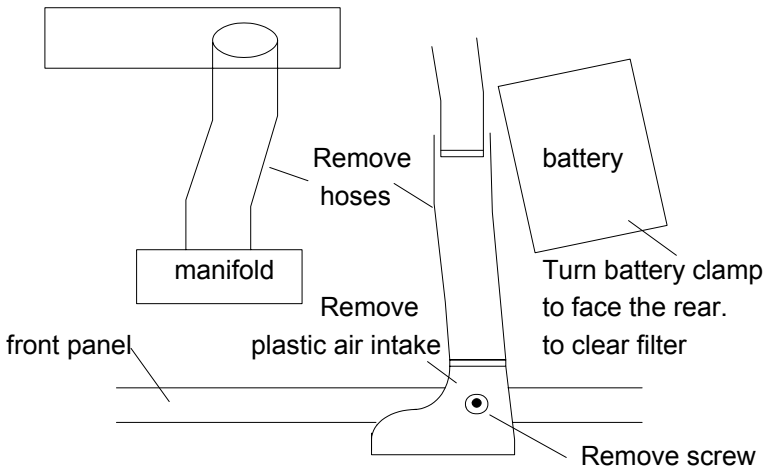

OFFSIDE VIEW

Front →

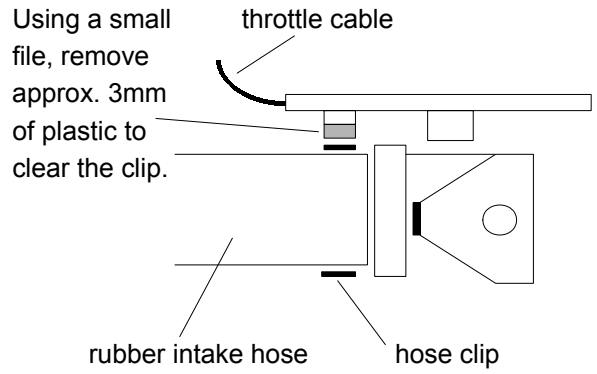

**Drawing C**

Hose should sit flat on fuel rail

Twist clamp to rear to clear filter

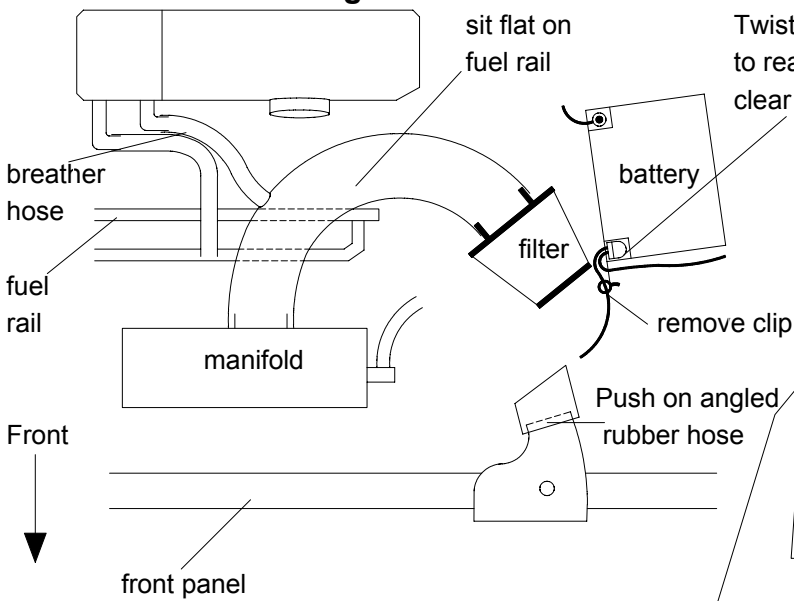

**Drawing D**

TOP VIEW

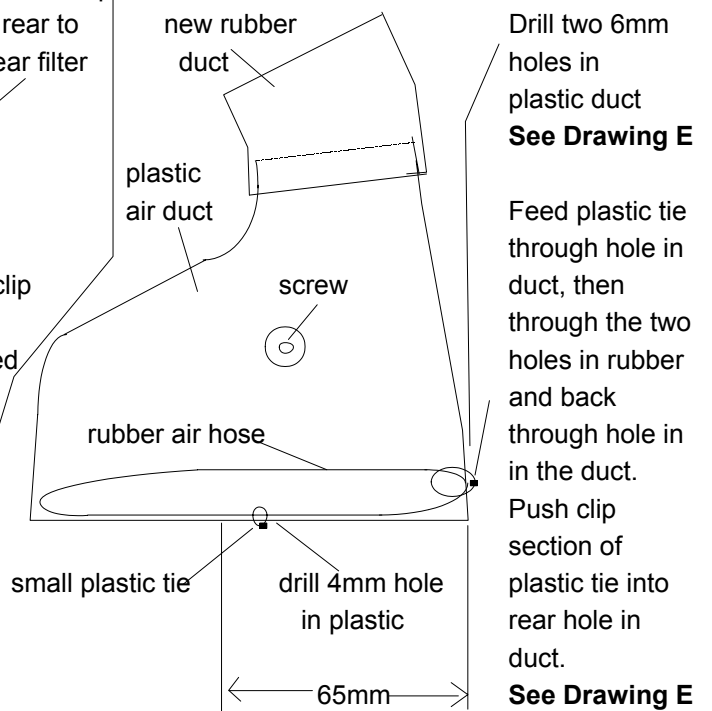

**Drawing E**

NEAR SIDE VIEW

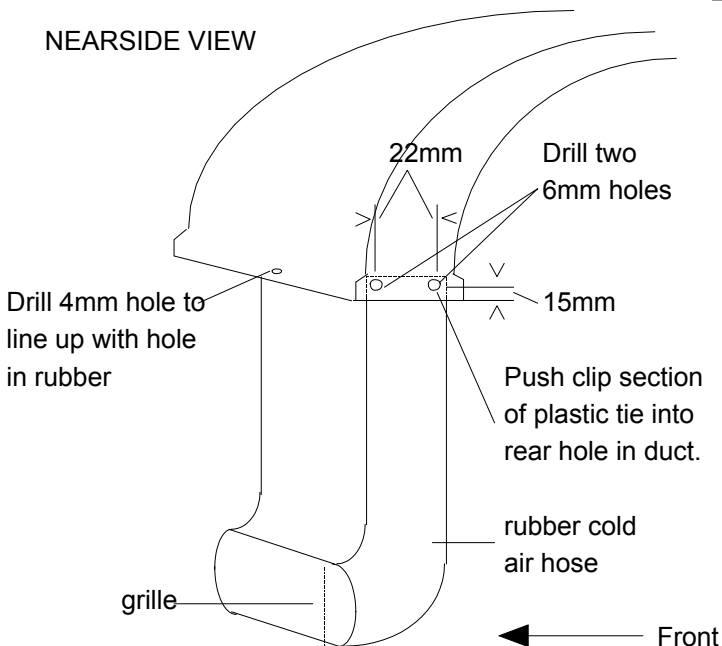

FRONT VIEW

