



AIRCHARGER™

HIGH-FLOW INTAKE KITS



INSTALLATION INSTRUCTIONS

63-1128
SUZUKI
2006-08 LTR450R

TOOLS NEEDED:

- 3mm Allen Wrench
- 6mm Allen Wrench
- 5mm Allen Wrench
- 10mm Socket
- 8mm Wrench
- 10mm Wrench
- 11mm Wrench
- Extension
- Flat Blade Screwdriver
- Ratchet

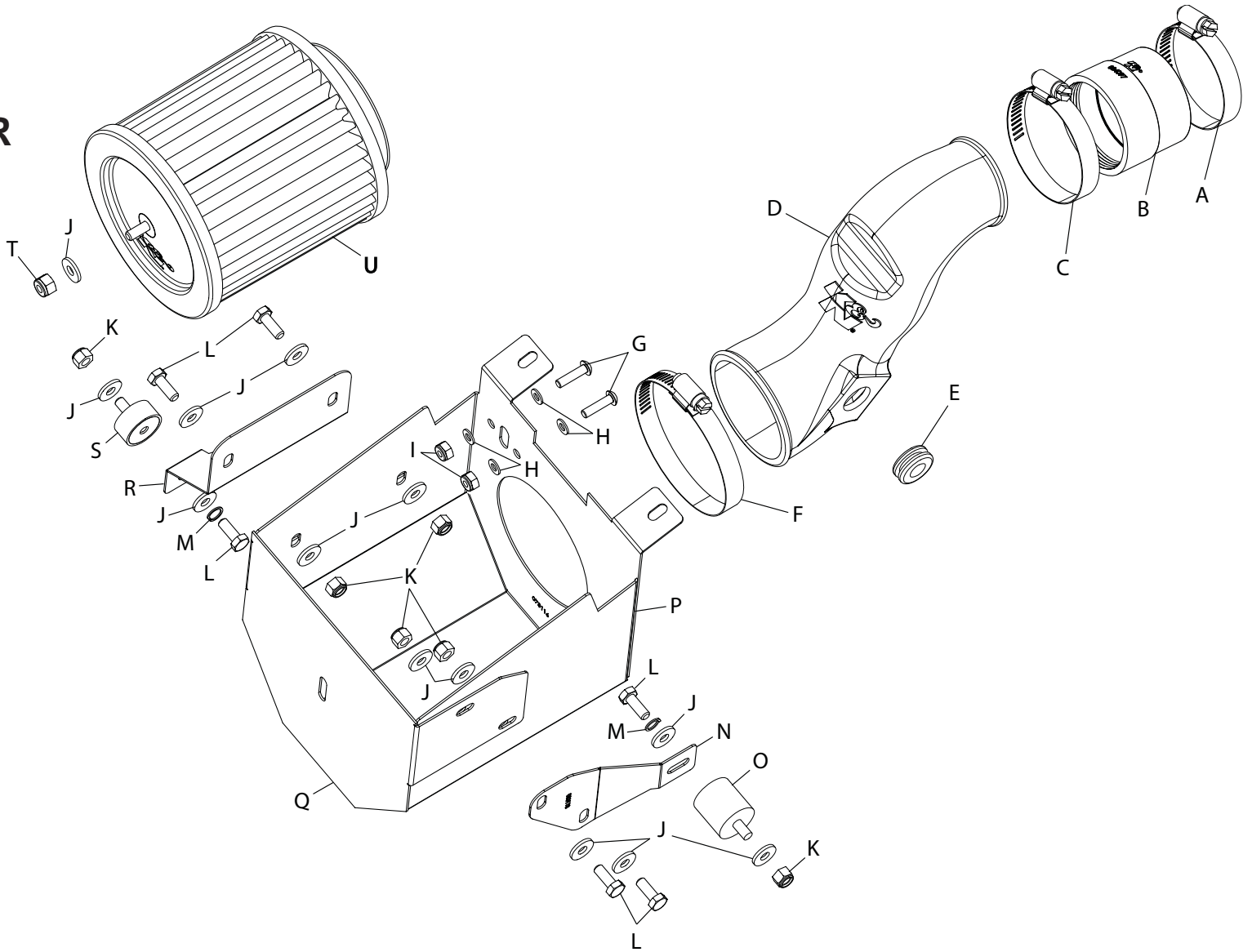

PARTS LIST:

Description	Qty.	Part #	Description	Qty.	Part #	Description	Qty.	Part #
A Hose Clamp #32	1	08507	H Washer; 5mm Flat, SS	4	08212	O Stud; Mtd, M6x1, 1" T, M/F	1	02033
B Silicone Hose	1	084097	I Nut; M5-0.8, Nylock, SS	2	07507	P Heat Shield	1	073116
C Hose Clamp #36	1	08530	J Washer; 1/4"IDx5/8"OD - SAE	13	08275	Q Heat Shield Cover	1	073115
D Intake Tube	1	087230	K Nut; 6mm Nylock, HexHd, SS	6	07512	R Bracket; TK/PC	1	083119
E Grommet; 7/16"ID	1	08092	L Bolt; 6mm-1.00x16mm, SS	6	07812	S Stud; M/F, 1/2"Lx1"W, M6x1.00	1	070228
F Hose Clamp # 48	1	08605	M Washer; 1/4" Lock, ZN	2	08198	T Nut; 1/4-20, Nylock, SS	1	07519
G Bolt; M5-0.8 X 20mm, HexHd, SS	2	22208	N Bracket; TK/PC	1	083118	U Air Filter	1	RC-5182XD

NOTE: FAILURE TO FOLLOW INSTALLATION INSTRUCTIONS AND NOT USING THE PROVIDED HARDWARE MAY DAMAGE THE INTAKE TUBE, THROTTLE BODY AND ENGINE.

TO START:

1. Turn off the ignition and disconnect the negative battery cable.



2. Release the seat latch and then remove the seat from the vehicle.



3. Remove the six bolts which secure the rear body work to the vehicle.



4. Remove the rear body work from the vehicle.



5. Loosen the clamp which secures the muffer inlet to the exhaust pipe.



6. Remove the two bolts which secure the muffer to the chassis and then remove the muffer assembly from the vehicle.



7. Disconnect the inlet air temperature sensor electrical connection.



8. Disconnect the crank case vent hose from the air box.



9. Loosen the hose clamp which secures the intake hose to the air box.



10. Remove the two bolts which secure the air box to the frame.

NOTE: There is one bolt on the left and right side of the air box.



11. Remove the air box assembly from the vehicle by sliding it forward and then pulling through the bottom of the chassis.

NOTE: It is a tight fit and must be positioned correctly to pull through the chassis. If necessary you can remove the sub frame to ease removal but this is not mandatory.



12. Loosen the hose clamp which secures the intake tube to the throttle body. Remove the intake tube from the vehicle.

NOTE: Depending on how the factory positioned the hose clamp, it may be difficult to loosen the hose clamp. K&N Engineering, Inc., recommends that customers do not discard factory air intake.



13. Install the provided silicone hose onto the throttle body and secure with the provided hose clamp.



14. Install the provided grommet into the intake tube as shown.



15. Install the intake tube into the silicone hose at the throttle body and secure with the provided hose clamp. Do not completely tighten at this time.



16. Insert the crank case vent fitting into the grommet installed into the intake tube as shown.



17. Remove the screws securing the inlet air temperature sensor and then remove the sensor from the factory air box.



18. Install the inlet air temperature sensor into the heat shield as shown and secure with the provided hardware.



19. Attach the heat shield back plate to the K&N® filter as shown and secure with the provided hardware.

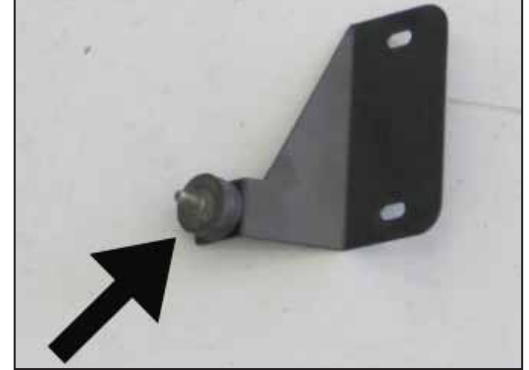

20. Install the short rubber mounted stud to the heat shield mounting bracket (083119) as shown and secure with the provided hardware.

NOTE: Do not completely tighten at this time.

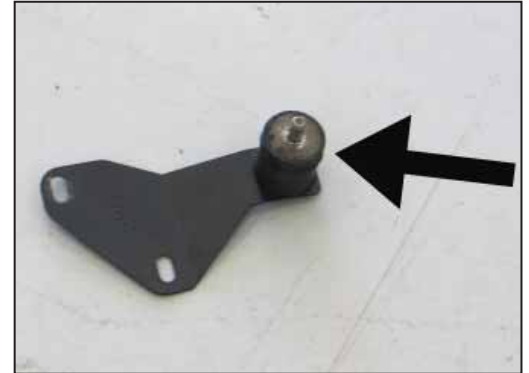

21. Install the long rubber mounted stud to the heat shield mounting bracket (083118) as shown and secure with the provided hardware.

NOTE: Do not completely tighten at this time.

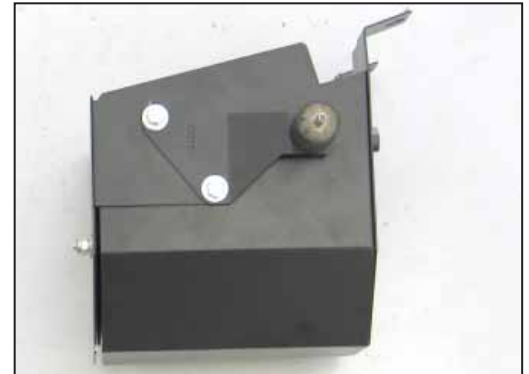

22. Install the filter and back plate assembly into the heat shield, align the mounting bracket assembly (083118) as shown and then secure with the provided hardware.

NOTE: Do not completely tighten at this time.



23. Align the mounting bracket assembly (083119) as shown and then secure with the provided hardware.

NOTE: Do not completely tighten at this time.

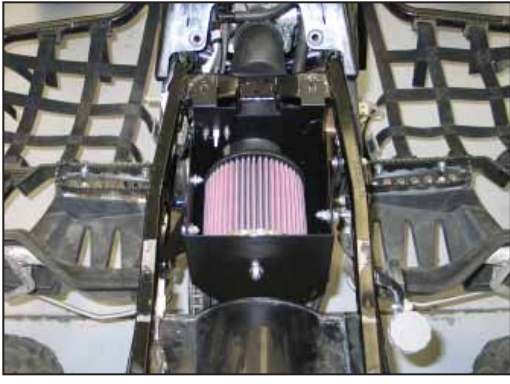

24. Install the heat shield and filter assembly into the frame from the bottom. Install the intake tube into the filter; install the rubber mounted studs into the air box mounting holes located in the frame tabs. Once the assembly is installed, secure the rubber mounted studs to the chassis with the provided hardware.

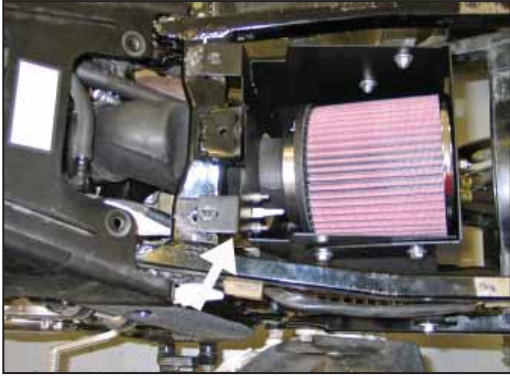

25. Reconnect the inlet air temperature sensor electrical connection.



26. Reinstall the rear body work and secure with the factory hardware.

NOTE: It will be necessary to align the heat shield before installing the top mounting bolts.



27. Tighten the hose clamps that secure the intake tube to the throttle body and air filter. Align the heat shield and tighten all of the mounting hardware.



28. Reinstall the muffler assembly and secure with the factory hardware.



29. Reinstall the seat.

30. Reconnect the negative battery cable.

31. Double check to make sure everything is tight and properly positioned before starting the vehicle.

32. It will be necessary for all K&N® high flow intake systems to be checked periodically for realignment, clearance and tightening of all connections. Failure to follow the above instructions or proper maintenance may void warranty.

ROAD TESTING:

1. Start the engine with the transmission in neutral or park. Listen for air leaks or odd noises. For air leaks secure hoses and connections. For odd noises, find cause and repair before proceeding. This kit will function identically to the factory system except for being louder and much more responsive.

2. Test drive the vehicle. Listen for odd noises or rattles and fix as necessary.

3. If road test is fine, you can now enjoy the added power and performance from your kit.

4. K&N Engineering, Inc., requires cleaning the intake system's air filter element periodically for excessive dirt build-up. When used in harsh terrain conditions or off-road environments, our filters will require cleaning more often. We recommend that you visually inspect your filter more frequently when used in harsh terrain conditions to determine if the screen is still visible. When the screen is no longer visible some place on the filter element, it is time to clean it. To clean and re-oil, purchase our filter Recharger® service kit, part number 99-5050 or 99-5000 and follow the easy instructions.

STREET LEGAL IN MOST STATES

**NOT LEGAL FOR USE IN CA & OTHER STATES
ADOPTING CA EMISSIONS STANDARDS**

See our catalog or knfilters.com for CARB status on each part for a specific vehicle

* FREE K&N® decal To register your warranty, please see us online at knfilters.com/register. FREE K&N® decal *