

INSTALLATION INSTRUCTIONS

69-3540TP
FORD
2018 Mustang GT
V8-5.0L

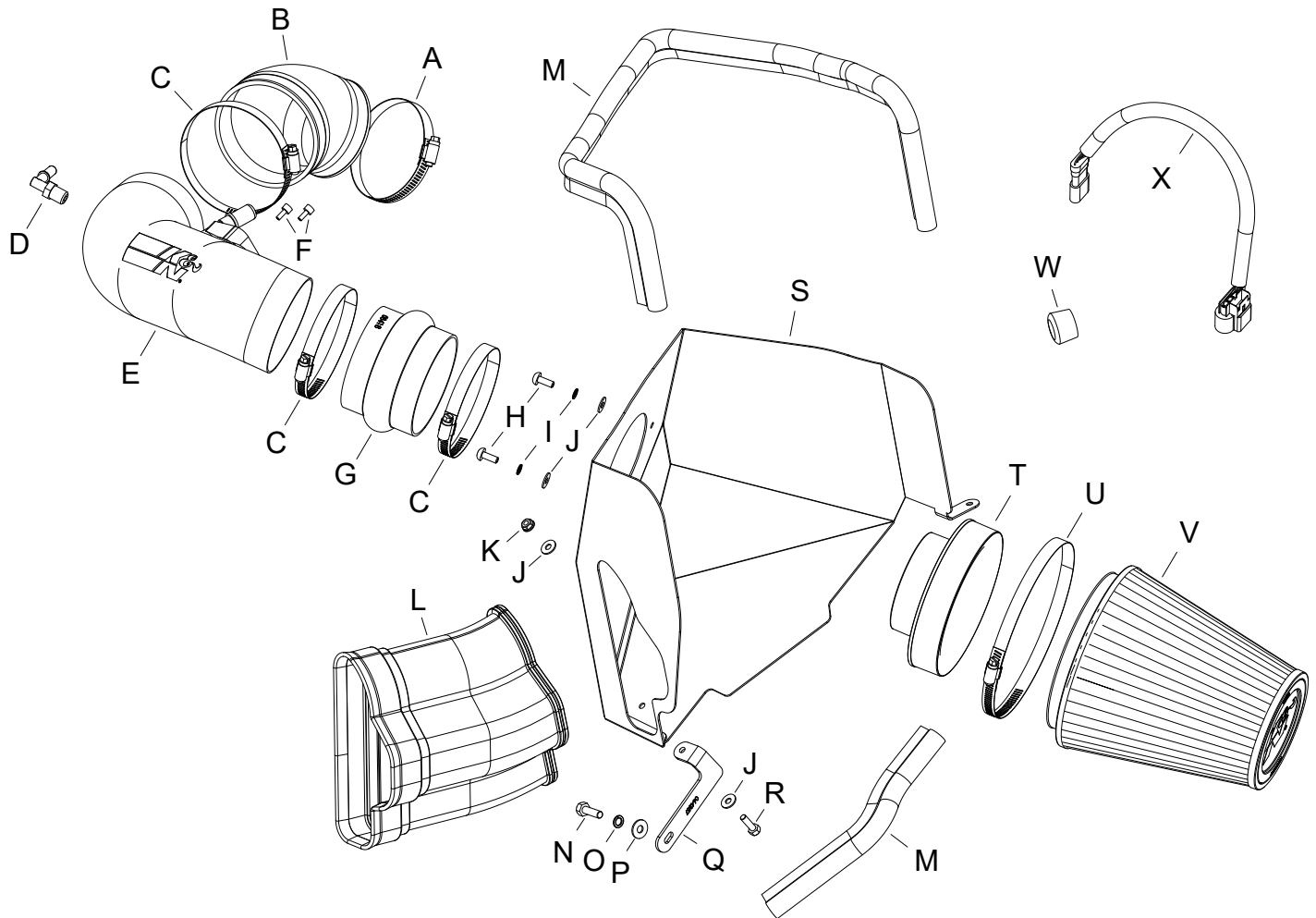

TOOLS NEEDED:

ratchet
 extension
 14mm socket
 10mm socket
 flat blade screw driver
 10mm wrench
 pliers

PARTS LIST:

Description	Qty.	Part #	Description	Qty.	Part #	Description	Qty.	Part #
A HOSE CLAMP; #56	1	08620	I WASHER, M6 SPLIT LOCK ZINC	2	1-3025	Q BRACKET; "L", 69-3540TP, STL	1	064357
B HOSE; COUPLER	1	5-1100	J WASHER; 6MM FLAT, SS	4	08269	R BOLT; 6MM-1.00 X 16MM, SS	1	07812
C HOSE CLAMP; #64	3	08645	K NUT; 6MM NYLOCK, HEXHEAD	1	07512	S HEAT SHIELD	1	073270
D VENT; 90°, 1/4NPT TO .375"	1	82632	L HOSE; FRESH AIR INTAKE	1	084106	T ADAPTOR; 57-3058 #454	1	27300
E INTAKE TUBE	1	25810P	M EDGE TRIM; 3/4" BULB, TOP	1	102481	U HOSE CLAMP; #104	1	08697
F BOLT; SOCKET 8-32 X 5/16" SS	2	1-2023	N BOLT; 8MM-1.25 X 16MM	1	07844	V 6"FLG, 7-1/2"B, 5-1/4"T, 6"H	1	RF-1042
G HOSE; HUMP 4"ID X 3"L	1	08418	O WASHER, M8 SPLIT LOCK ZINC	1	1-3036	W CAPLUG; 15/16" ID, 3/4" L, BLK	1	08246
H BOLT; M6 X 1.00 X 16MM, SS	2	07730	P WASHER; 8MM, FLAT, SS	1	08272	X MAF EXTENSION HARNESS	1	21780

If you need any assistance please call 1-800-858-3333 to speak with a representative in our Customer Service Center before returning the product.

NOTE: FAILURE TO FOLLOW INSTALLATION INSTRUCTIONS AND NOT USING THE PROVIDED HARDWARE MAY DAMAGE THE INTAKE TUBE, THROTTLE BODY AND ENGINE.

TO START:

1. Turn off the ignition and disconnect the negative battery cable.

NOTE: Disconnecting the negative battery cable erases pre-programmed electronic memories. Write down all memory settings before disconnecting the negative battery cable. Some radios will require an anti-theft code to be entered after the battery is reconnected. The anti-theft code is typically supplied with your owner's manual. In the event your vehicles anti-theft code cannot be recovered, contact an authorized dealership to obtain your vehicles anti-theft code.



2. Remove the four nuts that secure the strut tower brace and then remove the strut tower brace from the vehicle.



3. Remove the fastener covers on the engine cover, remove the two nuts that secure the cover and then remove the cover from the engine.



4. Disconnect the mass air sensor electrical connection.



5. Disconnect the vent lines and sound tube attached to the intake tube. Loosen the hose clamps that secure the intake tube to the air filter housing and throttle body and then remove the intake tube from the vehicle.



6. Release the one-time use clamp that secures the sound tube to the drum and then disconnect and remove the sound tube from the vehicle.



7. Remove the bolt that secures the air filter housing to the inner fender and then remove the lower air filter housing from the vehicle.
NOTE: K&N Engineering, Inc., recommends that customers do not discard factory air intake.

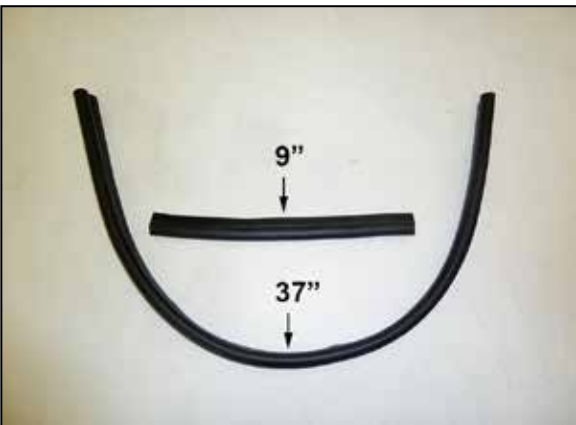

8. Cut the provided edge trim into two sections, One will be 9" long and the other will be 37" long.



9. Install the provided edge trim onto the K&N® heat shield as shown. Install the air filter adapter into the heat shield and secure with the provided hardware.



10. Install the provided mounting bracket (064357) onto the heat shield and secure with the provided hardware.



11. Install the provided fresh air duct into the heat shield as shown.



12. Install the heat shield assembly onto the inner fender and secure with the provided hardware.
NOTE: The K&N fresh air duct should be around the factory inlet duct.



13. Install the provided hump coupler (08418) onto the filter adapter and secure with the provided hose clamp.



14. Install the provided angled coupler hose (5-1100) onto the throttle body and secure with the provided hose clamp.



15. Install the provided 90° fitting into the K&N® intake tube. Remove the mass air sensor from the factory housing and install it into the K&N® intake tube using the provided hardware.
NOTE: Plastic NPT fittings are easy to cross thread. Install the vent fitting "hand" tight, then turn it two complete turns with a wrench.



16. Install the intake tube into the coupler at the throttle body and onto the coupler at the filter adapter, adjust the tube for best fit and then secure the tube to the coupling hoses with the provided hose clamp. Connect the EVAP and crank case vent lines to the fittings installed into the K&N® intake tube.



17. Reconnect the mass air sensor electrical connection using the provided extension harness.



18. Install the provided cap onto the sound drum as shown.



19. Install the K&N® air filter onto the filter adapter and secure with the provided hose clamp.
NOTE: Drycharger® air filter wrap; part # RF-1042DK is available to purchase separately. To learn more about Drycharger® filter wraps or look up color availability please visit <http://www.knfilters.com>®.



20. Reinstall the engine cover and secure with the factory hardware, reinstall the nut covers. Reinstall the strut tower brace and secure with the factory nuts.



21. Reconnect the vehicle's negative battery cable. Double check to make sure everything is tight and properly positioned before starting the vehicle.

22. It will be necessary for all K&N® high flow intake systems to be checked periodically for realignment, clearance and tightening of all connections. Failure to follow the above instructions or proper maintenance may void warranty.

ROAD TESTING:

1. Start the engine with the transmission in neutral or park, and the parking brake engaged. Listen for air leaks or odd noises. For air leaks secure hoses and connections. For odd noises, find cause and repair before proceeding. This kit will function identically to the factory system except for being louder and much more responsive.

2. Test drive the vehicle. Listen for odd noises or rattles and fix as necessary.

3. If road test is fine, you can now enjoy the added power and performance from your kit.

4. K&N Engineering, Inc., requires cleaning the intake system's air filter element every 100,000 miles. When used in dusty or off-road environments, our filters will require cleaning more often. We recommend that you visually inspect your filter once every 25,000 miles to determine if the screen is still visible. When the screen is no longer visible some place on the filter element, it is time to clean it. To clean and re-oil, purchase our filter Recharger® service kit, part number 99-5050 or 99-5000 and follow the easy instructions.

**LEGAL IN CALIFORNIA ONLY FOR RACING VEHICLES
WHICH MAY NEVER BE USED, REGISTERED
OR LICENSED FOR USE UPON A HIGHWAY.**

See knfilters.com for CARB status on each part for a specific vehicle